

PRODUCT CARD

BROHN 90cm Built-in Electric Oven

MODEL: BRO9001

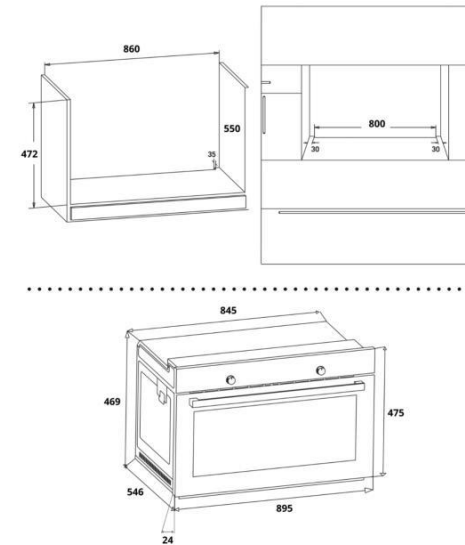

D (mm)	W (mm)	H (mm)	Cut-out D (mm)	Cut-out W (mm)
546	895	475	472	860

Features

Large Oven NET capacity: 100L

9 Functions with easy operating knob control , LED display

Durable to stain cavity with easy removable side racks for ease of cleaning

Triple-glazed, easy removable door and glass

Programmable clock / cut off timer

Energy Efficiency Class: A

Specifications

Supply Voltage: 220–240 V~ 50/ 60 Hz

Power Supply Max:2800W - 3400W
 Lower :1300W/ Upper :1050W/Medium grill: 2000W

Product Size D×W×H (mm): 546X895X475

Cut-out Dimensions D×W (mm): 472X860

Product Weight: 40 kg

Package Weight: 46 kg

Popular Functions

Fan Forced Oven

Grill Rotisserie with fan assist

Lower & upper heating elements fan forced

Turbo heat fan forced

Defrost

50 ~ 250°C temp. range