



# Trinity 45cm Compact Freestanding Dishwasher

**TRDWFS4510**



## KEY FEATURES

- 10 Place Setting Capacity
- INOX High Grade Stainless Steel Finish
- 8 Wash Programs
- Dual Zone Wash, Extra Drying Function
- LED Display
- 1-24 Hours Delay Start
- Child Lock
- Compact Universal Detergent Dispenser
- Concealed Heating Element
- Cutlery Draw
- Pull Out Upper and Lower baskets
- Height Adjustable Upper Basket

### GENERAL

Dishwasher type	Freestanding
Installation Type	Freestanding / Under-Benchtop (Lid Removed) 815mm - 860mm
Size	45 cm
Finish Colour	INOX High Grade Stainless Steel
Finish Colour Description	Stainless Steel Control & Door Panel with Silver Cabinet
Interior	Stainless Steel
Control Panel	Electrical Push Button
Display Panel	LED
Heating	Concealed Heating Element
Water Inlets	Cold Only
Cutlery Drawer	Yes
Accessories included	1 x 1800mm Cold Water Inlet Hose, 1 x 1600mm Drain Outlet Hose

### WARRANTY

Manufacturer Warranty	2 Years
Warranty Note	2-Year Domestic Warranty on all Parts & Labour

### SPECIFICATIONS

Capacity	10 Place Settings
Wash Programs	<ul style="list-style-type: none"> <li>• Eco</li> <li>• Glass</li> <li>• 90 Minute</li> <li>• Rapid</li> <li>• Pre-wash</li> <li>• Auto</li> <li>• Intensive</li> <li>• Heavy</li> </ul>
Extra Functions	Child Lock, Power Wash, Extra Drying
Water Consumption Use	11 Ltr/Cycle
Water Pressure	0.04-1.0MPa=0.4-10 bar
WELS Registration	D02557
Noise Level	49 dB

### POWER / RATINGS

Voltage Rating	220-240 V~ 50/ 60 Hz
Power Rating	Max 2.1 kW
Type Of Connection	10A plug & lead
Connection Requirements	This product requires a 10amp electrical connection
Length Of Cord	1.5 m
Energy Rating	3.5 Stars
Water Rating	3.5 Stars

### DIMENSIONS

Product Dim. (H x W x D)	845 x 448 x 600 mm
Product Weight	36 kg
Packed Dim. (H x W x D)	890 x 495 x 645 mm
Package Weight	41 kg

NOTE TO THE INSTALLER: Dimensions, specifications and drawings not to scale and to assist as a guide only. Trinity Appliances reserves the absolute and unrestricted right to change product materials and specifications, at any time, without notice. Physical product measurements of actual product must be taken prior to installation and making a cutout. Proper installation is the responsibility of the installer. Product failure due to improper installation is not covered under the Product Warranty.

1300615001 | trinityappliances.com.au



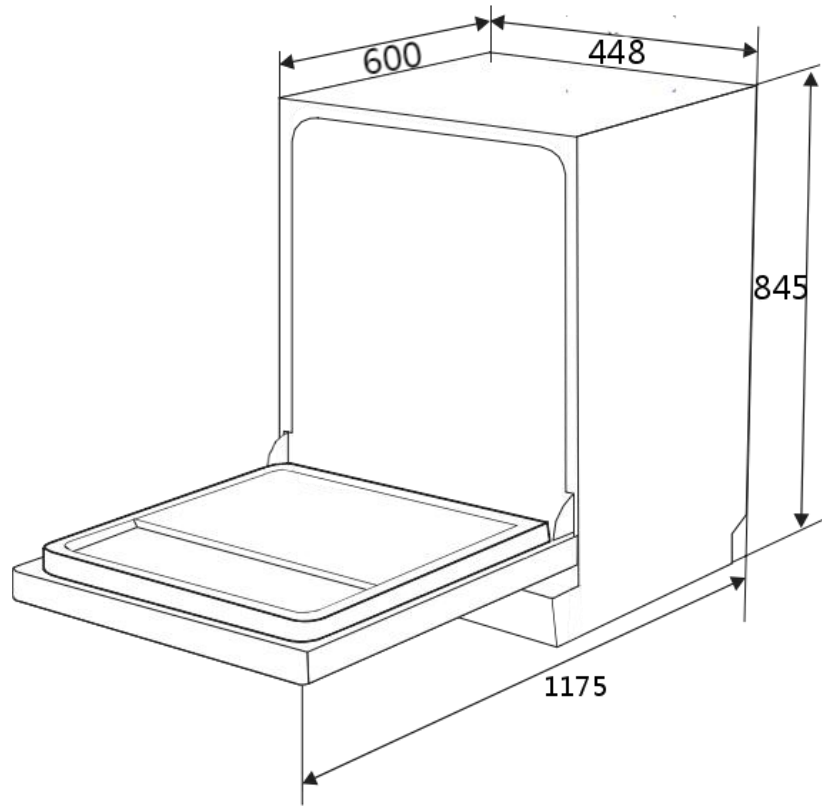

### PRODUCT DIMENSIONS

Width	Depth		Height
448mm	With the door closed: 600 mm (With top lid) 570 mm (Without top lid)	With the door opened: 1175 mm	With top lid: 845mm (Min) / 890mm (Max)  Without top lid: 815 mm (Min) / 860mm(Max)

Equipped and fitted with adjustable legs: 4 x 50mm

Removable top lid height: 30mm

NOTE TO THE INSTALLER: Dimensions, specifications and drawings not to scale and to assist as a guide only. Trinity Appliances reserves the absolute and unrestricted right to change product materials and specifications, at any time, without notice. Physical product measurements of actual product must be taken prior to installation and making a cutout. Proper installation is the responsibility of the installer. Product failure due to improper installation is not covered under the Product Warranty.