

# 60 cm Freestanding Electric Oven with Gas Cooktop

## TRFSEGO600



### KEY FEATURES

- ✓ Cast Iron Pan Support
- ✓ Flame Failure Device
- ✓ Pulse Ignition
- ✓ Bottom Drawer
- ✓ 3 Layer Cool-Touch Door
- ✓ Oven Heating Fan
- ✓ Wire Rack Support
- ✓ Cavity Capacity 65L
- ✓ Timer and oven lamp
- ✓ 150-250°temperature range

#### GENERAL

Type	Freestanding
Size	60 cm
Finish	Stainless Steel / Black Glass
Side Panels	Steel Silver Painted
Control Type	Knob Control with Multi-functions

#### OVEN FUNCTIONS

Cooking Functions	9
Oven Light	Yes
Fan Forced	Yes
Top Heat	Yes
Bottom Heat	Yes
Rotisserie	Optional

#### SPECIAL FEATURES

Cooling Fan	Yes
Splashback	Yes
Cavity Enameling Color	Black
Interior Oven Lights	1x Round Halogen
Adjustable Feet	Yes
Anti-Tip (Tilting) Bracket	Yes
Auto Re-Ignition	Yes
Fuel Type	NG / ULPG

#### OVEN DOOR

Oven Glass Window	"O" Shaped Metal + Glass
Door Cooling System	Cool Door 3 Pane Heat-Resistant Glass

#### ACCESSORIES / OVEN CAVITY

Rack Positions	5 Levels
Chromed Shelves/Racks	2
Net Capacity L	65 L
Oven Tray	Yes
LPG Conversion Kit	Yes

#### COOKTOP

Burner Configuration	4- Gas Sabaf Burners
Front Left	Rapid burner x 3000W
Rear Left	Aux burner x 1000W
Front Right	Semi rapid burner x 1750W
Rear Right	Semi rapid burner x 1750W
Pan Support Type	Continuous Cast Iron Pan Supports

#### POWER / RATINGS

KW/Amps rating	220-240 V 60 Hz 40 A 3kW
----------------	--------------------------

#### DIMENSIONS

Required cutout dim (H x W x D)	885 – 915 x 600 x 600 mm
Product Dim (H x W x D)	850 x 598 x 595 mm
Product Weight	55 kg
Packed Dim (H x W x D)	900x650x645 mm
Packed Weight	65 kg

NOTE TO THE INSTALLER: Dimensions, specifications and drawings not to scale and to assist as a guide only. Trinity Appliances reserves the absolute and unrestricted right to change product materials and specifications, at any time, without notice. Physical product measurements of actual product must be taken prior to installation and making a cutout. Proper installation is the responsibility of the installer. Product failure due to improper installation is not covered under the Product Warranty.

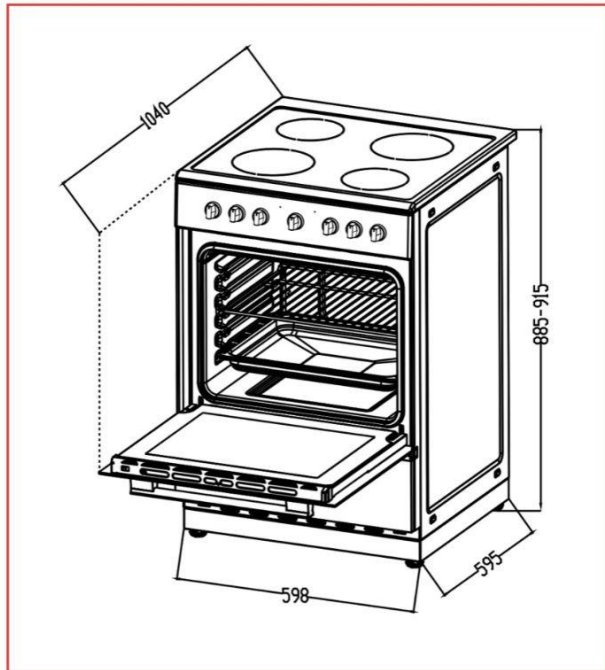

## Product Dimensions

Height: 850 mm  
 Width: 598 mm  
 Depth: 595 mm

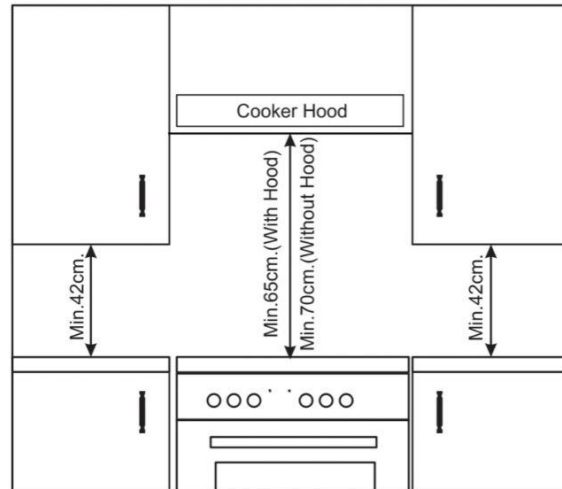

Figure 1

## Cabinetry Cut-Out Dimensions

885 - 915 mm  
 600 mm  
 600 mm

NOTE TO THE INSTALLER: Dimensions, specifications and drawings not to scale and to assist as a guide only. Trinity Appliances reserves the absolute and unrestricted right to change product materials and specifications, at any time, without notice. Physical product measurements of actual product must be taken prior to installation and making a cutout. Proper installation is the responsibility of the installer. Product failure due to improper installation is not covered under the Product Warranty.