



# 90cm Built-in Slideout Rangehood Stainless Steel

TR90S90-NP



## GENERAL

Installation	Built-in
Size	90 cm
Material	#430 Stainless Steel Body
Color	Silver
Control Design	Rocker Switch

## SPECIFICATIONS

Fan Speed	2-speed
Exhaust Air Power	750 cbm/h
Lighting	2x40W Normal bulb/1x2W LED(L14)
Filter	3 layers Aluminium Filer x 2
Flue	Not Included
Pipe	1.5m Aluminium Pipe

## AVAILABLE ACCESSORIES

Filter	Round Carbon Filter CP100
Flue	No

## POWER / RATINGS

Voltage Rating	220-240 V~ 50/ 60 Hz
Power Cord	No Plug

## DIMENSIONS

Product Dim. (H x W x D)	225 x 895 x 281 mm
Product Weight	11 kg
Packed Dim. (H x W x D)	950 x 270 x 360 mm
Package Weight	12 kg

## KEY FEATURES

- #430 Stainless Steel Body
- Aluminium Washable Filters
- 750 CBM/H Airflow
- Hardwire Connection
- Powerful 2-Speed Exhaust Motor

NOTE TO THE INSTALLER: Dimensions, specifications and drawings not to scale and to assist as a guide only. Trinity Appliances reserves the absolute and unrestricted right to change product materials and specifications, at any time, without notice. Physical product measurements of actual product must be taken prior to installation and making a cutout. Proper installation is the responsibility of the installer. Product failure due to improper installation is not covered under the Product Warranty.

1300615001 | [trinityappliances.com.au](http://trinityappliances.com.au)



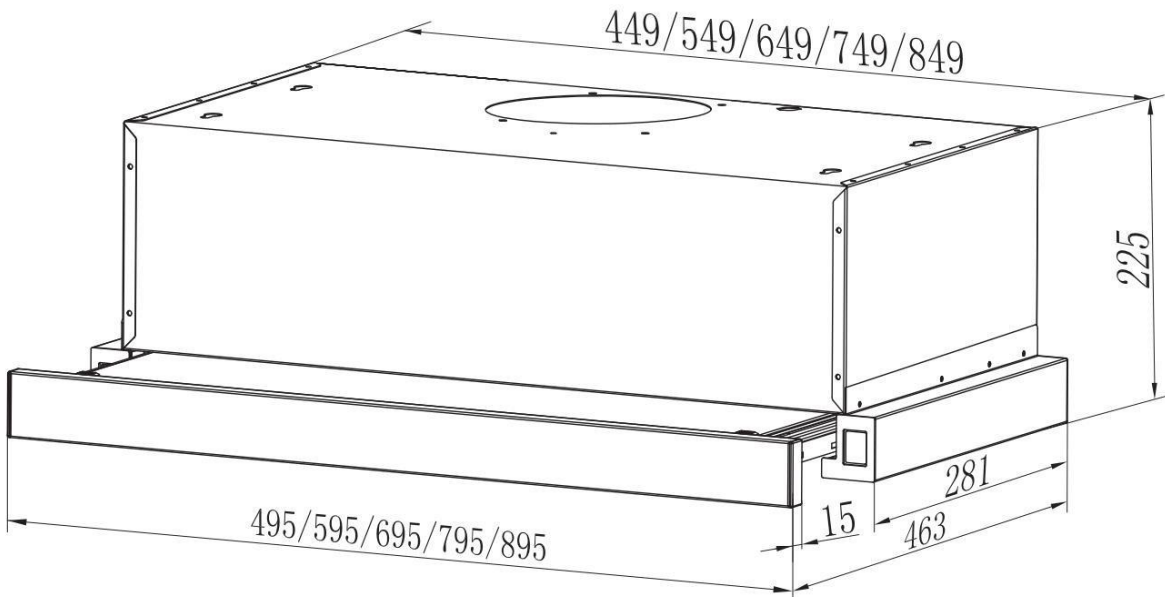

### Product Dimensions

Height: 225mm  
Width: 895mm  
Depth: 281/463mm

NOTE TO THE INSTALLER: Dimensions, specifications and drawings not to scale and to assist as a guide only. Trinity Appliances reserves the absolute and unrestricted right to change product materials and specifications, at any time, without notice. Physical product measurements of actual product must be taken prior to installation and making a cutout. Proper installation is the responsibility of the installer. Product failure due to improper installation is not covered under the Product Warranty.